



Electronic

TUBE

MAY - JUNE, 1946

HAM NEWS

Copyright 1946 by General Electric Company

VOL. 1 - NO. 1



TOP EFFICIENCY ON TEN!

Page 1 & 2—Constructional Data—GL-813 10 Meter Final • Page 3—Questions and Answers—Tricks and Topics • Page 4—GL-813 Technical Data

Push-Pull GL-813's Feature Vacuum Capacitor Tank Circuit with Butterfly Trimmer

High-efficiency, ultra-modern design and low driving power requirements headline the features of this 10 meter final, shown in Fig. 1, rated at 720 watts on c-w or 480 watts on phone.

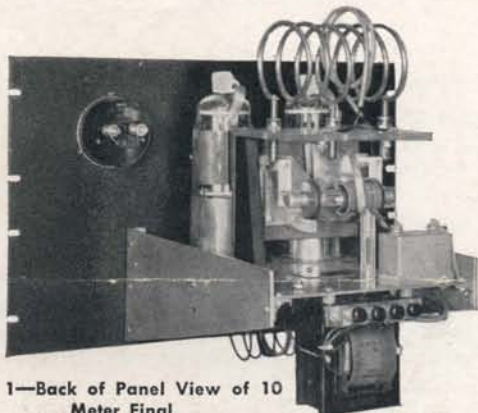

Fig. 1—Back of Panel View of 10 Meter Final

A GL-1L31 vacuum capacitor combined with a butterfly trimmer condenser in the plate tank circuit gives high over-all circuit efficiency. Proper placement of parts allows operation without neutralization on 10 meters and the lower frequency bands.

The coil constants given are for 10 meter operation, but a quick QSY may be made to 15 meters by removing the GL-1L31 vacuum capacitor (6 mmf) and inserting a GL-1L25 vacuum capacitor (12 mmf) in its place. The grid condenser tunes to either 10 or 15 meters with the coil pictured in Fig. 3. Although the grid coil is pictured permanently installed, provisions may be made for coil changing in order to work the lower frequency bands.

In actual on-the-air tests on 28.4 MC, a GL-807 doubler gave ample drive. With 550 volts on the plate of the GL-807, a grid current of twenty-five mils was obtained. This was cut down to 14 mils for phone work, and even less may be used for c-w. Varying the grid drive from 8 to 25 mils gave no appreciable change in output.

ELECTRICAL CIRCUIT

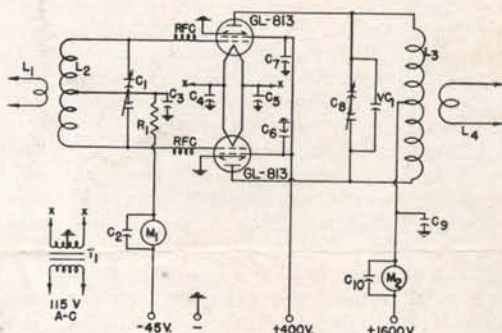

Fig. 2—Circuit Diagram of 10 Meter Final Using Push-Pull GL-813's

Circuit Constants

C₁ = Split-stator condenser, 70 mmf per section, .070 in. spacing (Cardwell MT-70-GD)
C₂C₁₀ = 0.01 mf 600 volt mica
C₃ = 0.002 mf 600 volt mica
C₄C₅ = 0.005 mf 600 volt mica
C₆C₇ = 0.002 mf 2500 volt mica
C₈ = Split-stator condenser, 12 mmf per section, see text for details
C₉ = 0.003 mf 5000 volt mica (Sangamo F2L-523)
VC₁ = Vacuum capacitor GL-1L31 (6 mmf 16,000 volts)
VC₂ = Vacuum capacitor GL-1L25 (12 mmf 16,000 volts)
R₁ = 10,000 ohm, 10 watt resistor

L₁ = Input link, 2 turns, No. 14 wire, 2 in. I.D.
L₂ = Grid coil, 6 turns, No. 12 wire, 2 in. I.D., 3 1/4 in. long
L₃ = Plate coil, 6 turns, 3/16 in. copper tubing, 2 5/8 in. I.D., 5 in. long
L₄ = Output link, 2 turns, No. 12 wire, 2 5/8 in. I.D.
RFC = Parasitic choke, 24 turns, No. 24 wire, 1/4 in. I.D., 1 1/4 in. long
M₁ = 0-30 ma. d-c meter (G-E Model 8DO41AAZ26)
M₂ = 0-500 ma. d-c meter (G-E Model 8DO41ABH7)
T₁ = Filament Transformer, 10 volts at 10 amps (Thordarson T-19F87)
Right Angle Drive = Millen No. 10012

As may be seen from the circuit diagram of Fig. 2, the grid circuit is standard in all respects. The grid tuning condenser (70 mmf per section) was chosen with a sufficiently high capacity to allow operation on the low frequency bands.

As shown in Fig. 3 it was necessary to mount the capacitor crosswise on the chassis in order to preserve electrical and mechanical symmetry—important on ten meters. A Millen right angle drive is mounted directly on the chassis bracket and a flexible coupling employed to drive the condenser. Some slight evidence of parasitic oscillations dictated the use of parasitic chokes in the grid leads. These are made of 24 turns of No. 24 wire, 1/4 inch in diameter and 1 1/4 inch long, self-supporting.

CQ CQ CQ

Lighthouse Larry wants you Hams to submit material for "Questions and Answers" and "Tricks and Topics" (see page three this issue).

Lighthouse Larry wants these two features to be full of live information, so get those letters rolling in. For each "question" or "trick" published in Ham News Lighthouse Larry will award \$10 worth of G-E tubes.

All entries become the property of the Electronics Dept., Tube Division, General Electric Company. What say, gang!

73's

Lighthouse Larry



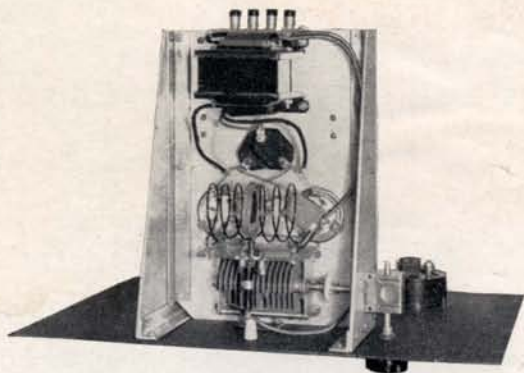

Fig. 3—Under-Chassis View of 10 Meter Final

The screen circuit is somewhat unusual in that each screen is individually by-passed to ground. Using a common by-pass lowered the circuit efficiency. The screen voltage is supplied from a separate source for c-w work. If a series resistor were used, the screen voltage would rise to the value of the plate voltage, and the tube would be damaged. For phone work a series resistor must be used so that the screen is modulated at the same time as the plate.

An alternate method of supplying screen voltage would be to use a series resistor from B+ to the screen, then another resistor from the screen to ground, forming a voltage divider circuit. In this case no change need be made from phone to c-w, and the only precaution that must be taken is to be sure that the screen voltage does not exceed 800 volts under key-up conditions.

The beam-forming plates must be connected to a point of zero d-c. The center-tap of the filament transformer may be used conveniently, although as shown in Fig. 3, satisfactory operation was obtained by tying the beam-forming plates to the chassis directly at the socket.

Exact electrical balance is maintained in the plate tank circuit by the use of a butterfly type split-stator condenser, with the vacuum capacitor in parallel. No neutralization is required as the tubes are sufficiently shielded, and the plate circuit is completely isolated from the grid circuit by the aluminum shelf.

The meters as pictured in Fig. 1 are not connected in the circuit, as connection is made to a separate cable in actual use. In the circuit diagram the plate meter is shown in the positive lead so that it indicates only plate current, not screen and plate current. Care must be taken to avoid contact with the plate meter while the high voltage is on.

Butterfly Condenser

A scale drawing of the butterfly condenser plates is given in Fig. 4. The plates may be cut from brass, the corners and edges rounded with a file, and then silver plated. The plates are assembled on a piece of $\frac{1}{8}$ in. mycalex with the first rotor plate between the mycalex and the first stator plate. Fig. 1 shows these details. Spacers between plates are $\frac{1}{2}$ in. long and $\frac{3}{8}$ in. in diameter. A $\frac{3}{4}$ in. long post is

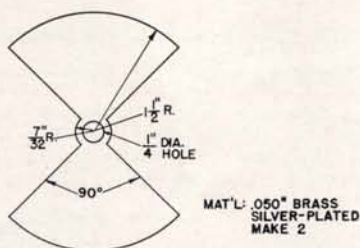
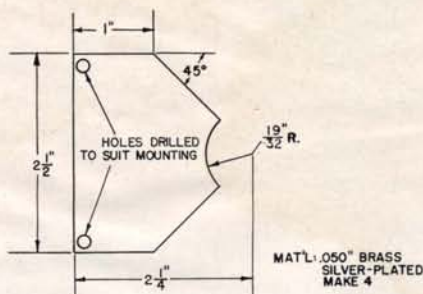

Fig. 4—Mechanical Layout of Butterfly Plates

brought out the rear of the capacitor on each side and a $\frac{1}{2}$ in. by a $1\frac{3}{4}$ in. strap fastened vertically.

Standard 30-ampere fuse clips are fastened to the two straps as Fig. 1 shows, to allow mounting the vacuum capacitor.

Mechanical Details

An 8 in. by 12 in. piece of $\frac{1}{8}$ in. aluminum is used as the main assembly mount. Aluminum angles, $\frac{3}{4}$ in. by $\frac{3}{4}$ in. join the brackets to the aluminum chassis and also join this assembly to the front panel as shown in Fig. 1.

The grid coil (Fig. 3) is mounted on a piece of polystyrene which in turn is mounted directly on the condenser stator connections. The individual screen by-pass condensers may be seen directly behind the coil (Fig. 3) where they tie to the chassis.

The butterfly condenser mount and plate-tank coil mount are pictured in Figs. 1 and 5. The upright supports are made of $\frac{1}{2}$ in. bakelite, drilled and tapped on the bottom for mounting. The mycalex support for the butterfly condenser is mounted on the front face of the bakelite support (Fig. 5). The polystyrene tank coil support is similarly drilled and tapped into the top of the bakelite supports.

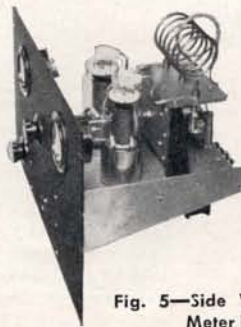

Fig. 5—Side View of 10 Meter Final

QUESTIONS AND ANSWERS



Do you have any questions about tubes or tube circuits? Lighthouse Larry would like to answer them for you. For each question published you will receive \$10 worth of G-E electronic tubes. All questions not published will be answered promptly by mail. Send your questions to Lighthouse Larry, Tube Division, Bldg. 269, General Electric Company, Schenectady, New York.

Question: If a radio-frequency amplifier (or oscillator) stage has its plate circuit tuned to resonance, and a link is then added in order to couple to the next stage, what change in plate tuning capacitance is required in order to resonate the circuit?—W8WFH

Answer: When the link is coupled to the plate coil the circulating current in the link sets up an e.m.f. which bucks the coil e.m.f. This effectively decreases the inductance of the coil so that it is necessary to ADD capacitance in the tank circuit in order to overcome the loss of inductance.—Lighthouse Larry

Question: Is it ever possible to neutralize a push-pull amplifier using only one neutralizing condenser, rather than the usual two, between one grid and the opposite anode?—W2JKY

Answer: Yes, it is practical to use single condenser neutralization in many applications. This type of

neutralization (in which the grid of one tube is tied to the anode of the other tube through a neutralizing condenser) is a method whereby one tube is neutralized by "plate" neutralization and the other tube neutralized by "grid" neutralization, both by the same neutralizing condenser.

In general, single condenser neutralization is most practical with tubes which have a low grid-plate capacitance and which have the least possible difference in their grid-plate capacities, from tube to tube. This means that tetrodes and pentodes are the most practical to neutralize by this method.

On the other hand, triodes may be used (up to 30 megacycles) if there is sufficient plate-tank KVA (high circulating current) to prevent unbalance.

At high frequencies (above 30 megacycles) it is desirable to split the single condenser into two condensers, of approximately equal values, one variable and one fixed, so that lead inductance is minimized. This is accomplished by wiring one condenser directly on the grid of one tube and the other condenser directly on the anode of the other tube. The lead joining the two condensers may then be any practical length.—Lighthouse Larry.



TRICKS AND TOPICS

How did you solve that last problem that almost had you stumped? Be it about tubes, antennas, circuits, etc., Lighthouse Larry would like to tell the rest of the hams about it. Send it in! For each "trick" accepted you win \$10 worth of G-E Electronic Tubes. No entries returned. Submit to Lighthouse Larry, Tube Division, Bldg. 269, General Electric Company, Schenectady, New York.

Two insulator ideas: (1) Used or scrap pieces of mycalex when powdered and mixed with water glass (sodium silicate) make an excellent high-voltage and high-frequency paste. After drying for from 4 to 8 hours it hardens in a form similar to the original material. The powder can be obtained by filing the mycalex, or grinding it on a grinder. The paste is extremely useful for sealing transformer windings, building up around bushings, or plugging up holes in insulators. It may also be molded into any form desirable. (2) After polystyrene has been worked or machined it assumes a translucent appearance. It may be made transparent by dipping it in carbon tetrachloride and allowing to dry without handling. This dipping

has the further advantage of thoroughly cleaning the polystyrene.—W8QLV.

In the construction of parasitic-element rotary beams, electrical thin-wall conduit makes excellent elements, being lightweight, strong and inexpensive. As the conduit comes in ten foot lengths, joints must be made in order to obtain the proper length. One convenient way to make a joint is to use silver-solder brazing. Any welder can do this job, and four or five joints should not cost over a dollar. As the heat destroys the galvanizing near the joint, an added precaution would be to paint the joint with aluminum paint after brazing. A second method of joining conduit is to use standard conduit couplers. In order to provide a low resistance r-f path, the couplers should be drilled out to remove the inner shoulder. A thin piece of copper, approximately 0.010 in. thick may then be wrapped around the joint, and the coupler slid over this copper joint. After adjustments have been made on the elements, the copper may then be soft soldered to the conduit on both sides of the joint. The galvanized surface of the conduit takes solder readily, and a good electrical joint is made.—W2GYV.

TECHNICAL INFORMATION

GL-813

GENERAL CHARACTERISTICS

Electrical

Cathode—Filamentary.	
Number of Electrodes.....	4
Filament Voltage, a-c or d-c.....	10.0 Volts
Filament Current.....	5 Amperes
Grid-plate Transconductance, $I_b = 50$ ma.....	3750 Micromhos
Direct Interelectrode Capacitances	
Grid-plate, with External Shielding.....	0.2 $\mu\mu\text{f}$
Input.....	16.3 $\mu\mu\text{f}$
Output.....	14 $\mu\mu\text{f}$

MAXIMUM RATINGS AND TYPICAL OPERATING CONDITIONS

CLASS C R-F POWER AMPLIFIER AND OSCILLATOR

(Key-down conditions per tube without modulation)

	Typical Operation			Maximum Ratings	
Filament Voltage.....			10.0		Volts
D-c Plate Voltage.....	1250	1500	2000	2000	Volts
D-c Grid Voltage †.....				-300	Volts
From a fixed supply of.....	-60	-70	-90		Volts
From a cathode resistor of.....	285	340	455		Ohms
From a grid resistor of.....	8500	11700	30000		Ohms
D-c Screen Grid Voltage †.....				400	Volts
From a fixed supply of.....	300	300	400		Volts
From a series resistor of.....	42000	60000	107000		Ohms
D-c Plate Current.....	180	180	180	180	Ma
D-c Grid Current, Approx.....	7	6	3	25	Ma
D-c Screen Grid Current.....	23	20	15		Ma
Plate Input.....				360	Watts
Plate Dissipation.....				100	Watts
Screen Grid Input.....				22	Watts
Peak R-f Grid Input Voltage, Approx.....	145	150	160		Volts
D-c Suppressor Voltage.....	0	0	0		
Driving Power, Approx.....	1	0.8	0.5		Watt
Plate Power Output.....	155	190	260		Watts

† Obtained from fixed supply, by grid resistor (8500, 11700, 30,000) or cathode resistor (285, 340, 455). If preceding stage is keyed, partial fixed bias is required.

‡ Obtained from a separate source, or from a series resistor of value shown. Series screen resistor should be used only where the 813 is used as buffer amplifier and is not keyed. The screen voltage must not exceed 800 volts under key-up conditions.

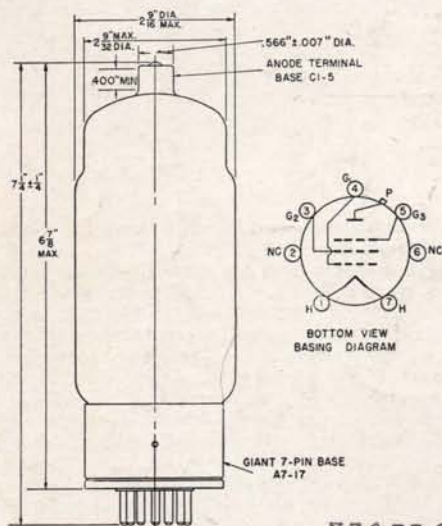

GL-813 OUTLINE

VAN SICKLE RADIO CO.

CH 1814 1113 PINE ST. LOUIS

Electronics Department

GENERAL ELECTRIC

Schenectady, N. Y.